

Base Plate Detail
Scale 1:2

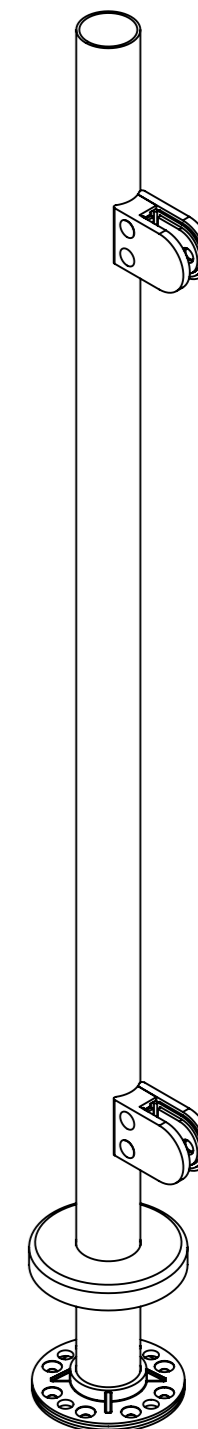
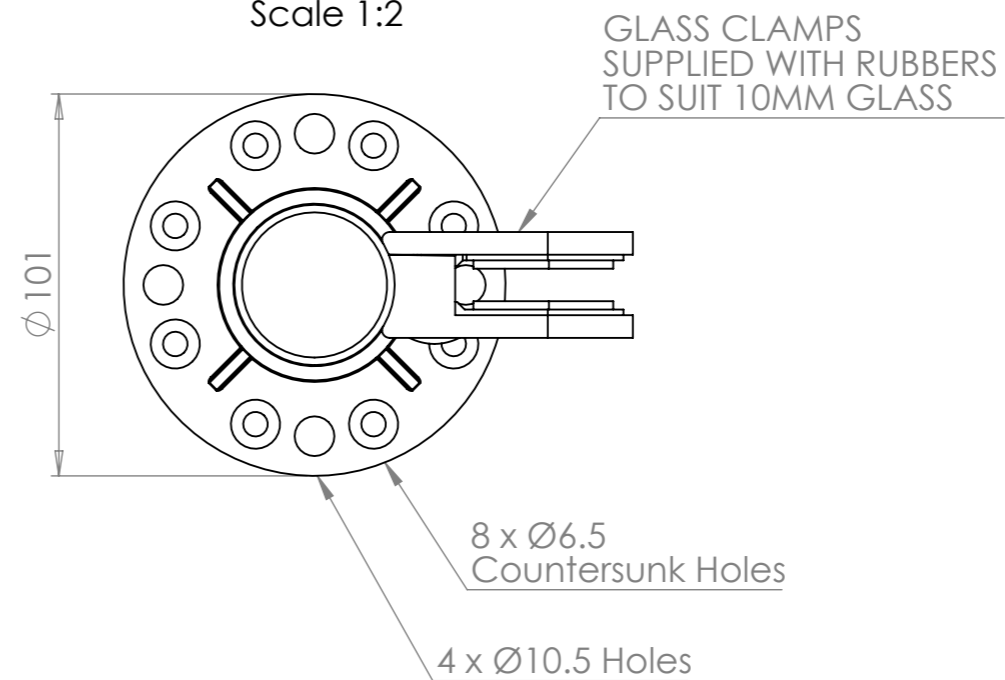

Part Code	Material	Finish	Grit Size
1804761C	304 Stainless	Satin Polished	320
1806761C	316 Stainless	Satin Polished	320
1806761CM	316 Stainless	Mirror Finish	800

DESCRIPTION: 42.4mm End Rail with Welded Base & Cover 2 x Clamps, Without Top, 1100mm High

	NAME	DATE	REVISION	UNLESS OTHERWISE SPECIFIED ALL DIMENSIONS ARE IN MILLIMETERS	A3
DRAWN	EF	27/06/19	E		
CHECKED				DO NOT SCALE DRAWING	SCALE:1:5