

## WHEN ORDERING PALISADE FENCING PLEASE STATE:

1. TYPE OF PALE - TRIPLE POINTED, SINGLE POINTED, ROUNDED OR ROUNDED & NOTCHED
2. WHAT PALE SECTION - 'D' OR 'W'
3. THICKNESS OF PALE
4. HEIGHT OF PALE
5. METRE RUN REQUIRED

## GATES

WE SUPPLY GATES OF THE HIGHEST QUALITY (BS1722) AND TAILOR-MADE TO SUIT YOUR REQUIREMENTS.

PLEASE PHONE OUR SALES TEAM FOR A COMPETITIVE QUOTE.



## WHEN ORDERING GATES THESE QUESTIONS WILL BE ASKED:

1. HEIGHT OF PALES
2. TYPE OF PALE
3. DISTANCE BETWEEN POSTS
4. DO THEY OPEN IN OR OUT. DO THEY NEED TO OPEN 90° OR 180°

IF IN DOUBT ASK OUR SALES TEAM TO FAX OVER A FORM WHICH CAN HELP CALCULATE WHICH GATES YOU REQUIRE.

IF YOU DO NOT SEE WHAT YOU REQUIRE IN THIS BROCHURE,  
PLEASE PHONE OUR SALES DESK FOR ASSISTANCE.

# F.H.BRUNDLÉ

WHOLESALE DISTRIBUTORS SINCE 1889

### SOUTH & WEST

502 Millbrook Road  
Third Avenue,  
Millbrook  
SOUTHAMPTON  
Hants SO15 0JX

Tel: 023 8070 3333  
Fax: 023 8070 5555

### LONDON & SOUTH EAST

Bow Industrial Park  
Carpenters Road  
LONDON  
E15 2DZ

Tel: 020 8525 7100  
Fax: 020 8525 7124

### EAST MIDLANDS & NORTH

Condor Road  
Quarry Hill Ind. Estate  
ILKESTON  
DE7 4RE

Tel: 0115 930 2070  
Fax: 0115 951 2455

### WEST MIDLANDS

Unit 6, Dorset Road  
Saltley Business Park  
Saltley  
BIRMINGHAM  
B8 1BG

Tel: 0121 327 8999  
Fax: 0121 327 8555

### NORTH WEST

2, Swan Meadow Mill  
Swan Meadow Road  
WIGAN  
Lancashire  
WN3 5BD

Tel: 01942 236 888  
Fax: 01942 826 689



# PALISADE FENCING



**F.H.BRUN্ডLE**  
WHOLESALE DISTRIBUTORS SINCE 1889



# PALISADE FENCING

PALISADE FENCING OFFERS THE ULTIMATE IN SECURITY. THIS SYSTEM IS EASY TO ASSEMBLE, AND ONCE ASSEMBLED OFFERS A FENCING SYSTEM THAT IS ROBUST, LONG LASTING AND A FORMIDABLE DETERRENT AGAINST CRIME AND VANDALISM.

## PALE TOPS



Triple Pointed \*



Single Pointed

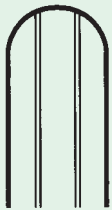

Rounded

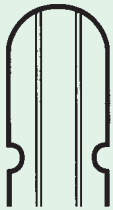

Rounded & Notched

## PALE PROFILES



'D' Section



'W' Section

### Materials thickness - 'D' Section

- \* 3.0mm For General Purpose use
- 3.5mm For Security Purpose use
- 4.0mm For High Security use

### Materials thickness - 'W' Section

- 2.0mm For Light Duty use
- 2.5mm For General Purpose use
- 3.0mm For Security Purpose use

**WE STOCK TRIPLE POINTED D SECTION  
3.0mm THICK 1800/2100/2400/3000mm HIGH**

## FINISH

ALL STEEL PALISADE PRODUCTS ARE GENERALLY SUPPLIED HOT DIP GALVANISED TO BS729 TO GIVE LONG TERM WEATHER RESISTANCE.

PALES CAN ALSO BE SUPPLIED IN A PLAIN MILD STEEL FINISH OR POWDER COATED TO YOUR RAL COLOUR SPECIFICATION.

FENCE HEIGHT mm	HORIZONTAL RAIL ANGLE SECTION	POSTS			SUPPORT FEET	
		R.S.J	LENGTH mm	CENTRES	No. PER BAY	LENGTH mm
1800 *	45 x 45 x 6	102 x 44 x 7.4	2400	2750	1	455
2000	45 x 45 x 6	102 x 44 x 7.4	2625	2750	2	455
2100 *	45 x 45 x 6	102 x 44 x 7.4	2725	2750	2	455
2400 *	45 x 45 x 6	102 x 44 x 7.4	3125	2750	2	610
3000 *	50 x 50 x 6	102 x 44 x 7.4	3925	2750	2	610

\* STOCKED ITEM

## OTHER HEIGHT PALES ARE AVAILABLE ON REQUEST

OUR PALES ARE SECURED TO THE CROSS RAIL USING M8 BOLT AND CONE NUTS. POST CENTRES ARE AT 2750mm FOR PALES UP TO AND INCLUDING A HEIGHT OF 3000mm.

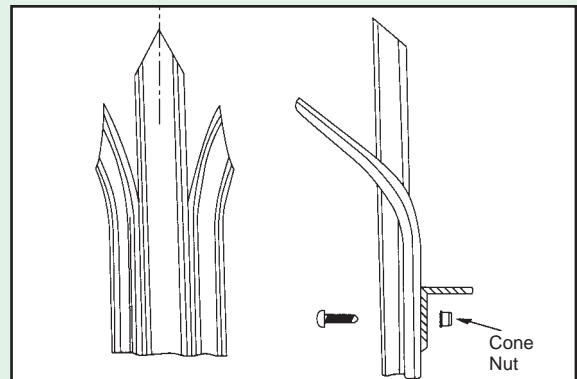
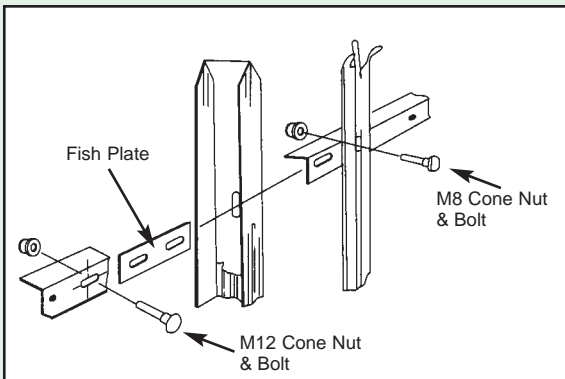
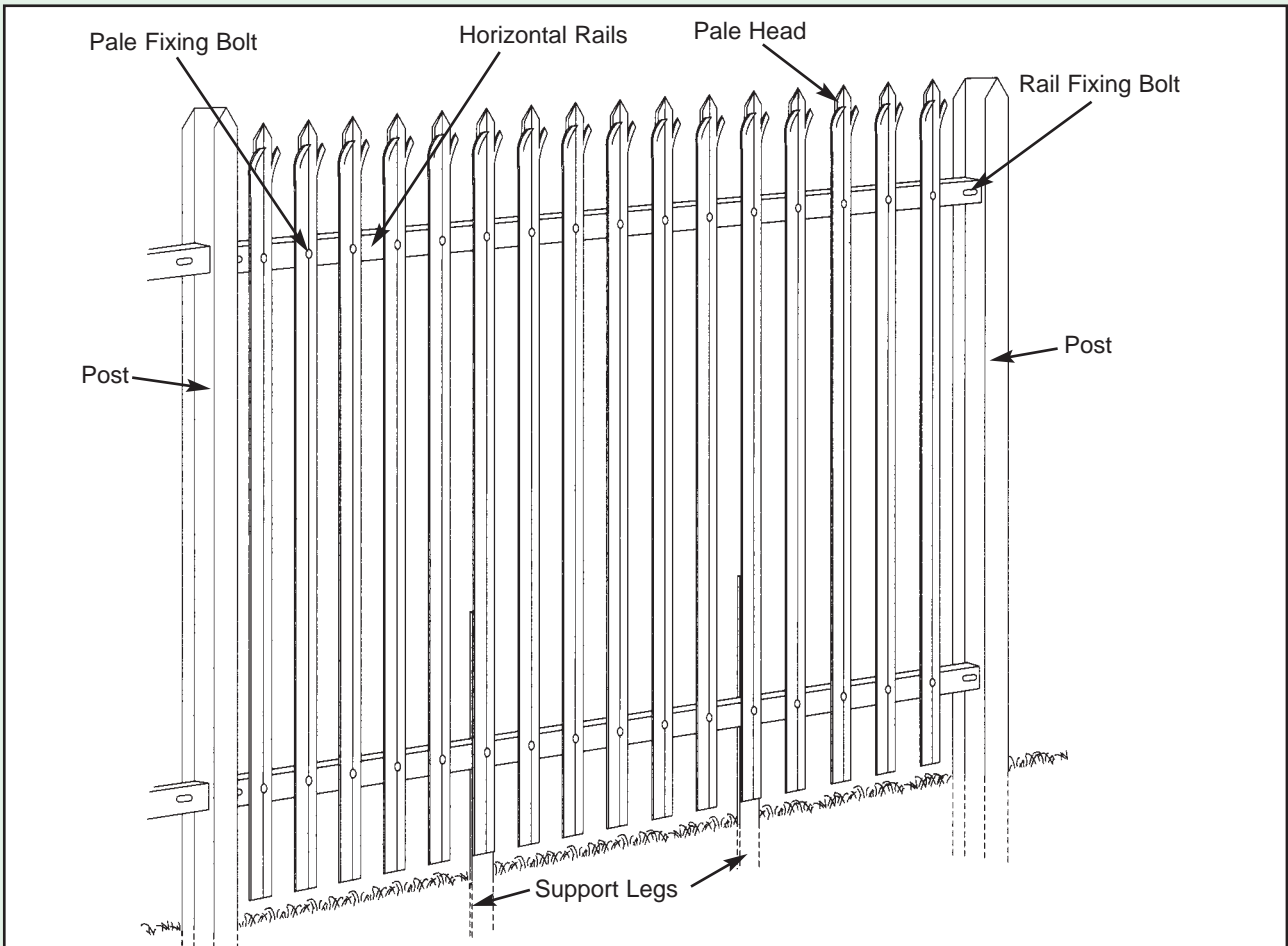

PALISADE FENCING IS SUPPLIED IN KIT FORM. ITS DESIGN ALLOWS THE FENCE TO BE ERECTED, SO THAT IT CAN FOLLOW THE CONTOURS OF THE GROUND.

BOLT DOWN POSTS FOR FIXING TO CONCRETE CAN ALSO BE SUPPLIED.

**FOR USE WITH FIXING PALES TO RAILS**



**M8 SADDLEBOLT:**

M8 saddlehead bolt with cone snap off tamper proof nut, suitable for use with general purpose and special purpose fences.

**FOR USE WITH HORIZONTAL RAILS**



**M12 BOLT:**

M12 cup square bolt with cone snap off tamper proof nut, suitable for use with general purpose and special purpose fences.